

Notes:

Read the notes on all pages before starting installation.

A. OVERVIEW

1. The loop system consists of two arrays of loops.
2. The loops must be installed and wired as shown in the drawings.
3. Equipment required to drive the loop arrays is shown below.
4. The loops should be installed on the floor using flat copper tape and adhesive installation tape under the floor finish (carpet).
5. The feed wires between each amplifier and the relevant array should be no more than 10m long, assuming that these feed wires are a pair of insulated 2.5mm² copper wires twisted tightly together. If the feed wires must be longer, this may affect the equipment specification, or a different feed wire may be needed. Please contact Ampetronic for advice if this is an issue.

B. REFERENCE POINT DRAWING.

This shows the origin point to which all dimensions on the design drawings are referenced.

Before starting installation, locate this point within the room.

It is suggested that you mark the 'X' and 'Y' axes on the floor before starting measurement or marking out.

If you cannot mark an axis in some part of the room (e.g. there are obstructions), derive a dimension line offset from the axis by a known (and preferably simple) amount.

C. SETUP

1. The amplifiers should be set to about the same output current for each unit.
2. The loop current would be 3.0A (RMS) per amplifier if there were no loss. The actual current required will depend on the loss experienced in practice. The equipment specified here will compensate for up to 5.0dB of loss.
3. The loss figure above has been estimated and no guarantee of actual performance can be given, although every effort has been taken to give realistic estimates of performance. If the effect of metal is greater than estimated, additional drive equipment may be required.
4. The field strength target should be 0dB +/-3dB re: 0.4Am⁻¹ (RMS) in the areas of good coverage.
5. Field strength outside the room (spill) should not be greater than the following levels (if the loops are installed accurately):
Adjacent areas: -40dB re: 0.4Am⁻¹(RMS)
This system has not been designed to minimise spill between adjacent floors.

Equipment needed to install the loop system in each room to this design:

Order as	Description	Unit size	Quantity
ILD500	Induction Loop Driver	1	2
SP5 - xxxx	Phase Shift / Metal Loss Corrector	1	1
RM-1U	Rack mount tray for 1U range	1	1
BRP-1U	Blank rack panel 1U high	1	1
FB 1.8	Flat insulated cable 1.8mm ²	50m roll	3
PWT	Adhesive Installation / Warning tape	50m roll	3

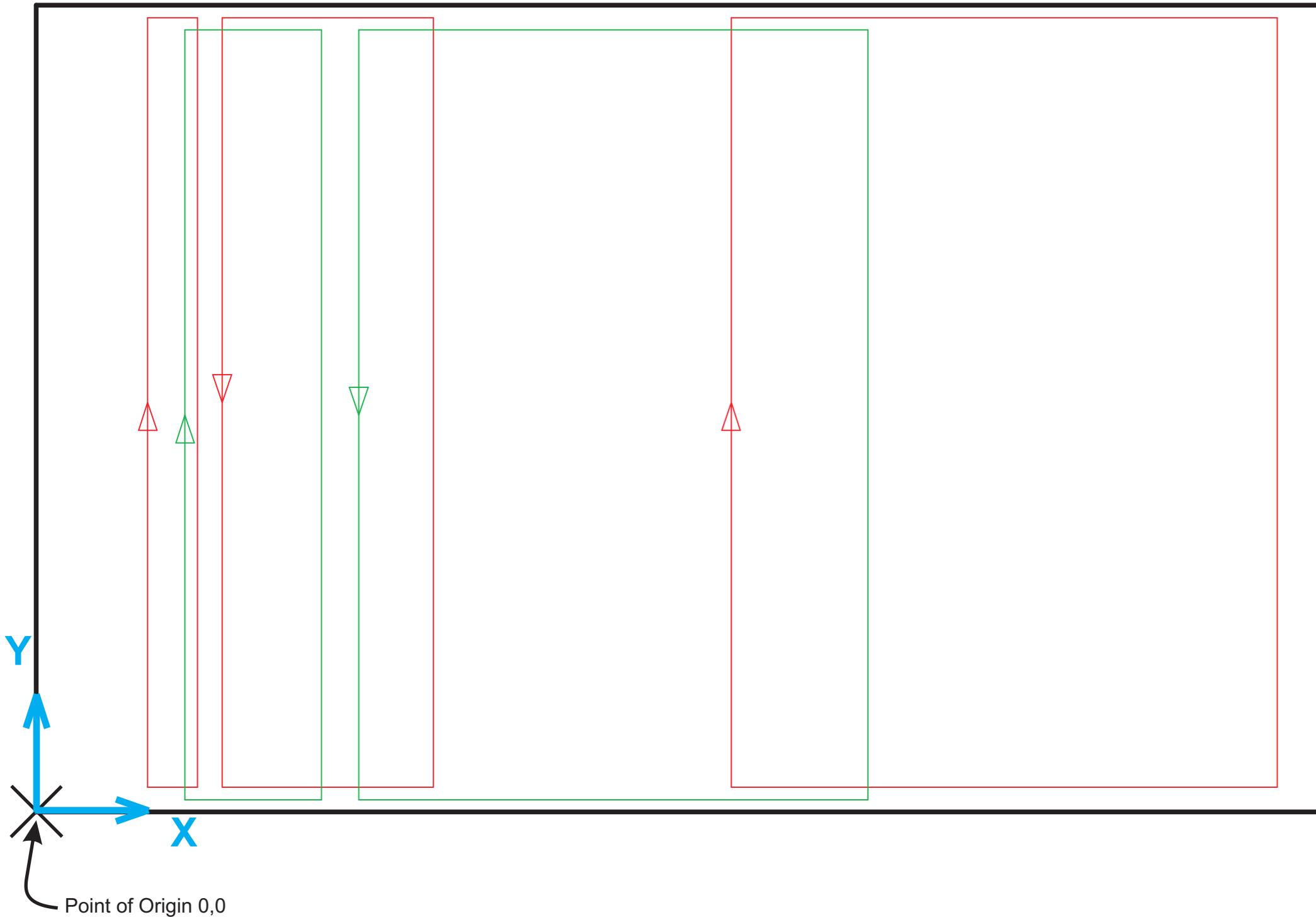

 www.ampetronic.com		Northern Road Newark Nottinghamshire NG24 2ET (+44) 01636 610062	
Client:	Client' Name		
Project:	Project's Name		
Drawing:	System Overview & Drawing Reference Point		
Dwg No:	DPxxxx/x/1	Issue 1	Scale: NTS
Drawn:	xxx	Date: xx/xx/xxxx	Chkd: xxx
Room:	Room 1	Sheet 1 of 5	

Notes:

Read the notes on every page before starting installation.

Where the term 'wire' is used in these notes, this can also refer to flat copper tape.

A. LOOP ARRAY DIMENSIONS

1. The loops **must** be installed to the dimensions shown on the drawing. If the wires are not correctly installed, performance within the room may not meet required standards.
2. Loop dimensions are all shown in metres relative to the reference point. This reference point is shown on drawing DPxxx/x/1 (a plan of the room with the reference point added).
3. Tolerance for the dimensions of any point is plus / minus 50mm.
4. The loop designs have been prepared using drawings that purport to show all obstructions in the floor (and areas where loop wires may not be placed).
5. In some cases, additional obstructions may be found which were not on the original drawings. If the deviation required to go around such an obstruction is not more than 400mm long (along the original line of the loop wire) and up to 300mm sideways, the loop wire may follow a small diversion around the obstruction.
6. If any deviation is larger, you should contact Ampetronic Ltd for advice. In such a case, other changes to the loop design may be needed if performance is to be maintained.

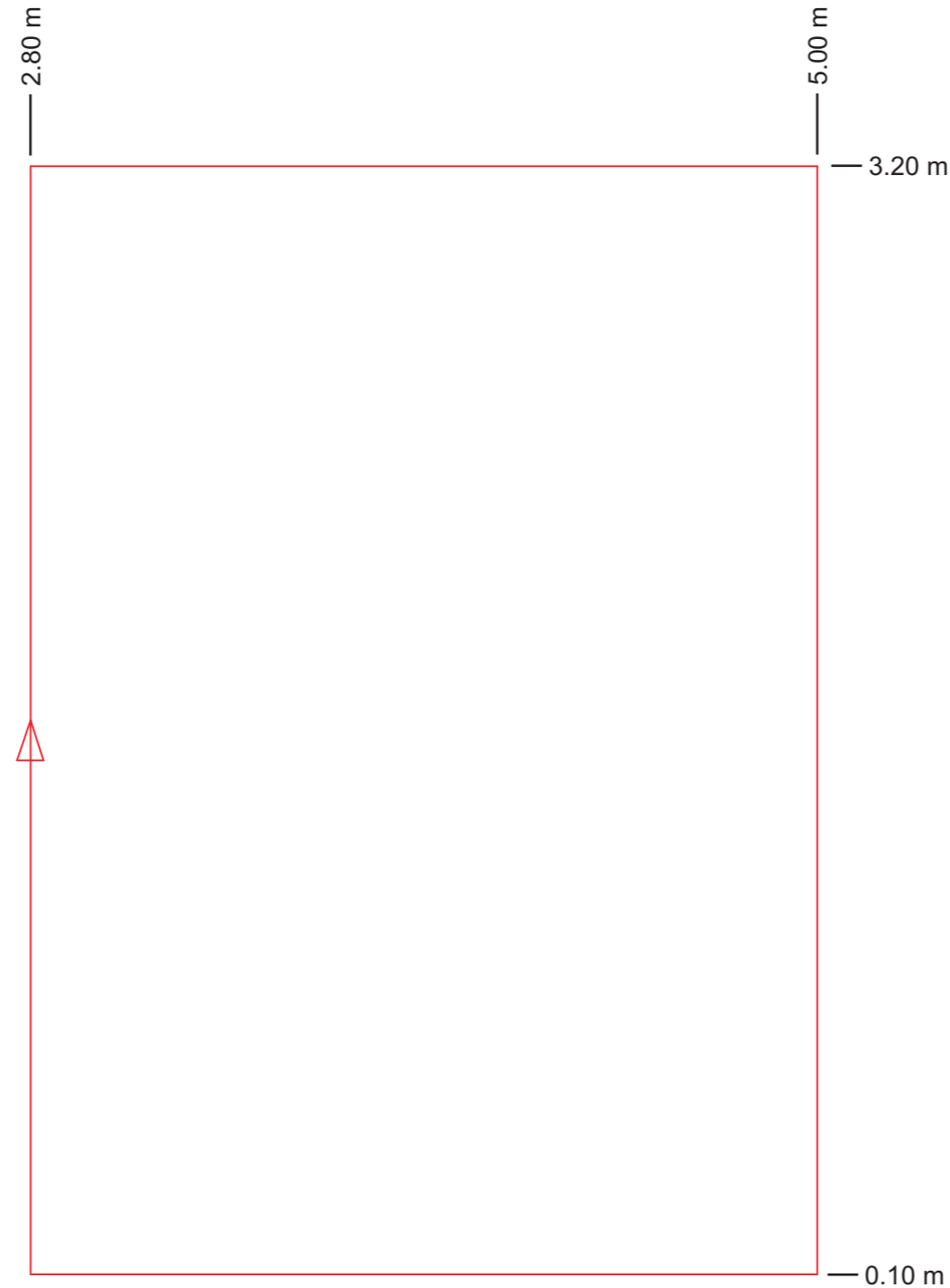
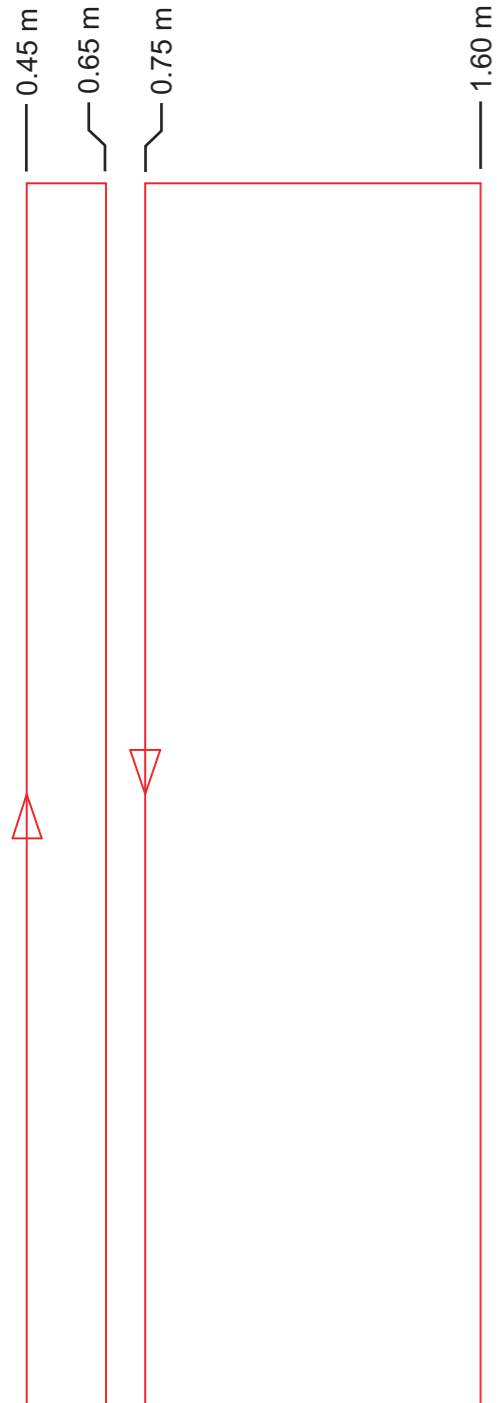

		Northern Road Newark Nottinghamshire NG24 2ET (+44) 01636 610062	
Client:	Client' Name		
Project:	Project's Name		
Drawing:	Loop Dimensions Array A		
Dwg No:	DPxxx/x/2	Issue 1	Scale: NTS
Drawn:	xxx	Date: xx/xx/xxxx	Chkd: xxx
Room:	Room 1	Sheet 2 of 5	

Notes:

Read the notes on every page before starting installation.

Where the term 'wire' is used in these notes, this can also refer to flat copper tape.

A. LOOP ARRAY DIMENSIONS

1. The loops **must** be installed to the dimensions shown on the drawing. If the wires are not correctly installed, performance within the room may not meet required standards.
2. Loop dimensions are all shown in metres relative to the reference point. This reference point is shown on drawing DPxxx/x/1 (a plan of the room with the reference point added).
3. Tolerance for the dimensions of any point is plus / minus 50mm.
4. The loop designs have been prepared using drawings that purport to show all obstructions in the floor (and areas where loop wires may not be placed).
5. In some cases, additional obstructions may be found which were not on the original drawings. If the deviation required to go around such an obstruction is not more than 400mm long (along the original line of the loop wire) and up to 300mm sideways, the loop wire may follow a small diversion around the obstruction.
6. If any deviation is larger, you should contact Ampetronic Ltd for advice. In such a case, other changes to the loop design may be needed if performance is to be maintained.

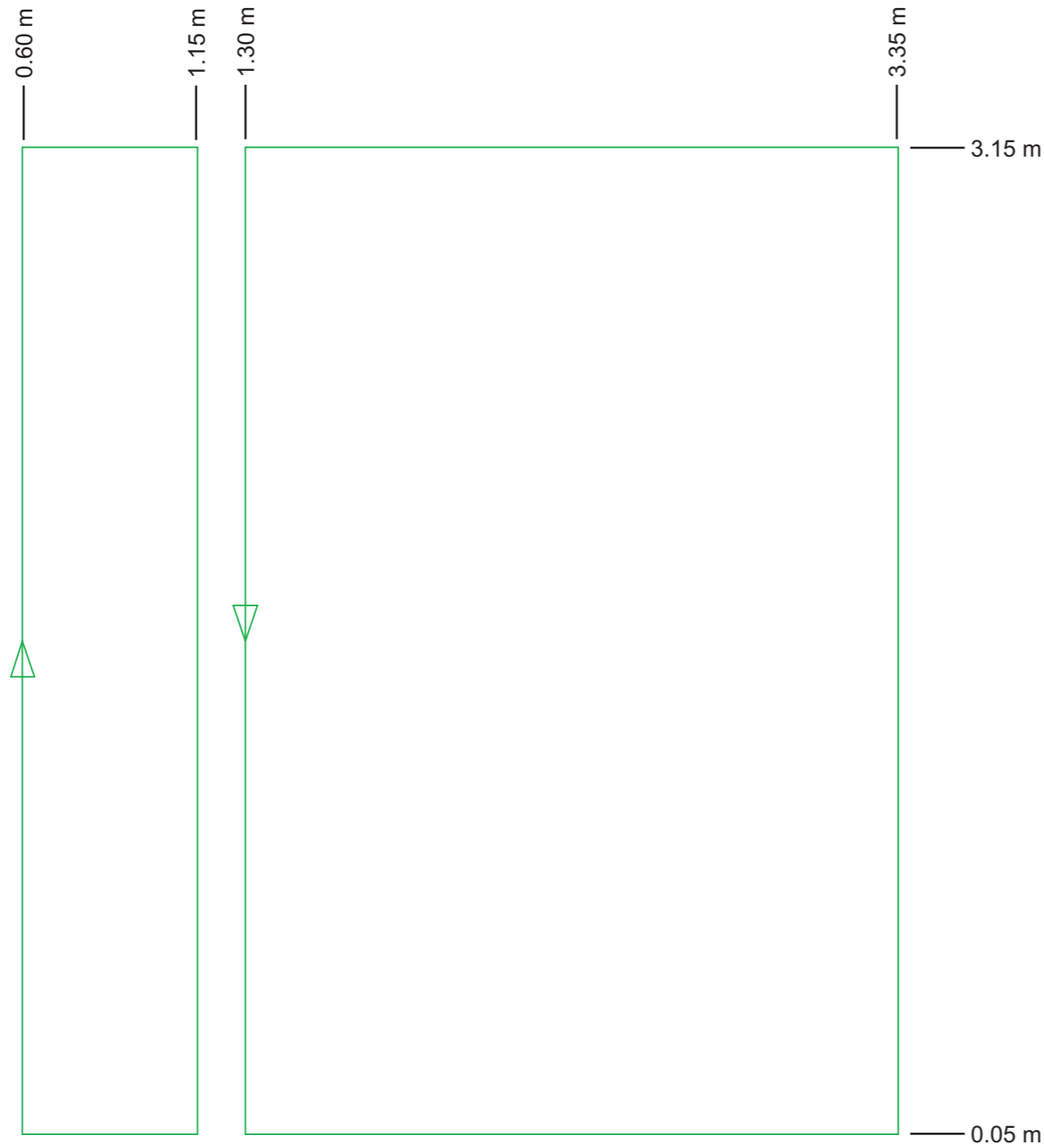

 www.ampetronic.com		Northern Road Newark Nottinghamshire NG24 2ET (+44) 01636 610062	
Client:	Client' Name		
Project:	Project's Name		
Drawing:	Loop Dimensions Array B		
Dwg No:	DPxxx/x/3	Issue 1	Scale: NTS
Drawn:	xxx	Date: xx/xx/xxxx	Chkd: xxx
Room:	Room 1	Sheet 3 of 5	

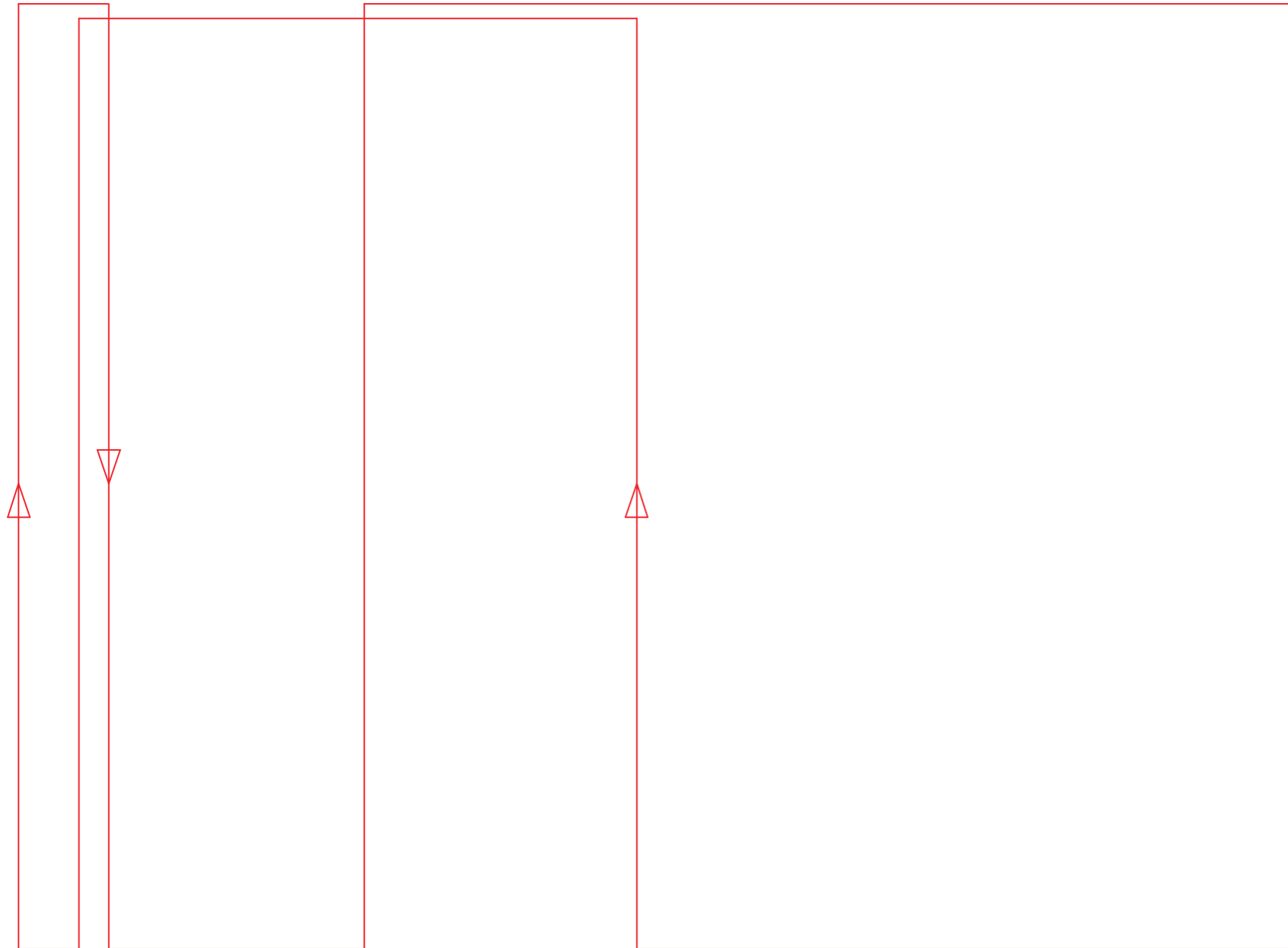

Connections between loops are shown exaggerated for clarity on the wiring drawing above.

Expanded detail of typical connection / link:

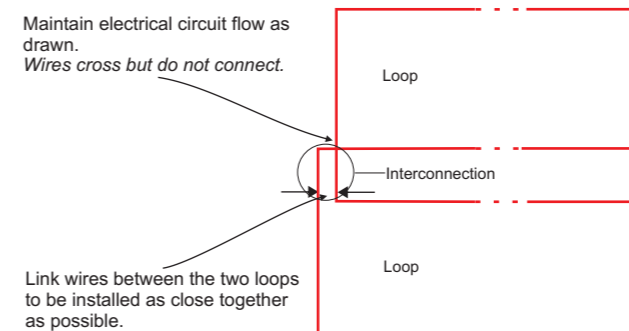

Notes:

Read the notes on every page before starting installation.

Where the term 'wire' is used in these notes, this can also refer to flat copper tape.

A. ELECTRICAL CONNECTIONS

1. The electrical connection drawings are circuit schematics and are not to scale. Some elements may be exaggerated to maintain clarity of the electrical connections.
2. The electrical connection pattern must be installed with the polarity of loops as shown. If you do not install the loop connections as shown, the system performance can be expected not to meet standards in some areas, and spill outside the room is likely to increase.
3. You should break the loop wire path at one point to connect the feed wires from the amplifier driving this array. This 'feed point' is not marked on the drawing; you can place it **anywhere** along the loop path that is convenient and practical.
 - 3a. If you need to make a feed point at the side of the room, and the designed loop array does not pass through your feed location, you can run two tapes very close together from the nearest point of the loop to your feed point.
4. All loop elements of this array are connected in series; there is only one electrical path from one side of the feed point, through *all* the loop elements, and back to the other side of the feed point.

B. INSTALLATION

Suggested Installation method:

1. For each array of a design, mark out the loop dimensions on the floor (using chalk or similar - you can use a different colour for each of the two arrays).
2. Start at one side of the feed point for the array in question, and lay out the wire along the path of the electrical current flow.
3. At each corner, secure the wire in place, and continue around the whole of that array.
4. If correctly installed, you should pass along every wire element of the array once, and you should return to the other side of the array's feed point.
5. Repeat the exercise for the second array.
6. Connect the loop amplifiers through the feed cable, and then connect your audio input system.
7. Test the loop system using a suitable test signal and loop receiver. You should, wherever possible, use field strength measuring equipment to determine that the correct field strength and frequency response have been achieved.

 www.ampetronic.com		Northern Road Newark Nottinghamshire NG24 2ET (+44) 01636 610062			
		Client:	Client' Name		
Project:	Project's Name				
Drawing:	Electrical Connections Array A				
Dwg No:	DPxxx/x/4	Issue 1	Scale:	NTS	
Drawn:	xxx	Date:	xx/xx/xxxx	Chkd: xxx	
Room:	Room 1	Sheet 4 of 5			

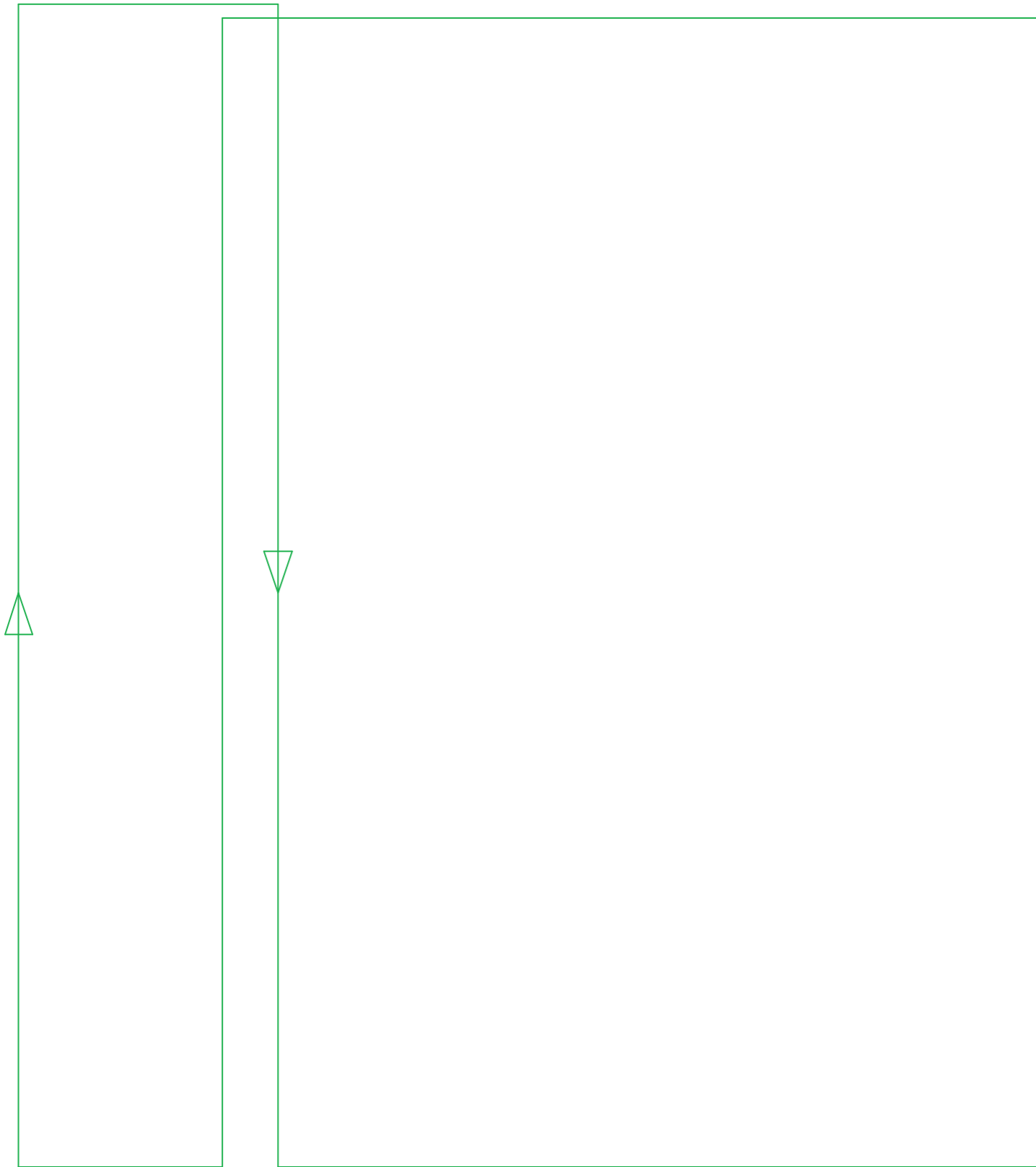

Notes:

Read the notes on every page before starting installation.

Where the term 'wire' is used in these notes, this can also refer to flat copper tape.

A. ELECTRICAL CONNECTIONS

1. The electrical connection drawings are circuit schematics and are not to scale. Some elements may be exaggerated to maintain clarity of the electrical connections.
2. The electrical connection pattern must be installed with the polarity of loops as shown. If you do not install the loop connections as shown, the system performance can be expected not to meet standards in some area, and spill outside the room is likely to increase.
3. You should break the loop wire path at one point to connect the feed wires from the amplifier driving this array. This 'feed point' is not marked on the drawing; you can place it **anywhere** along the loop path that is convenient and practical.
 - 3a. If you need to make a feed point at the side of the room, and the designed loop array does not pass through your feed location, you can run two tapes very close together from the nearest point of the loop to your feed point.
4. All loop elements of this array are connected in series; there is only one electrical path from one side of the feed point, through *all* the loop elements, and back to the other side of the feed point.

B. INSTALLATION

Suggested Installation method:

1. For each array of a design, mark out the loop dimensions on the floor (using chalk or similar - you can use a different colour for each of the two arrays).
2. Start at one side of the feed point for the array in question, and lay out the wire along the path of the electrical current flow.
3. At each corner, secure the wire in place, and continue around the whole of that array.
4. If correctly installed, you should pass along every wire element of the array once, and you should return to the other side of the array's feed point.
5. Repeat the exercise for the second array.
6. Connect the loop amplifiers through the feed cable, and then connect your audio input system.
7. Test the loop system using a suitable test signal and loop receiver. You should, wherever possible, use field strength measuring equipment to determine that the correct field strength and frequency response have been achieved.

Connections between loops are shown exaggerated for clarity on the wiring drawing above.

Expanded detail of typical connection / link:

Maintain electrical circuit flow as drawn. Wires cross but do not connect.

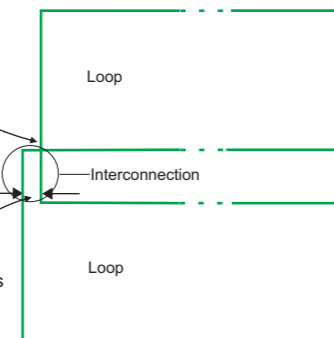

Link wires between the two loops to be installed as close together as possible.

AMPETRONIC www.ampetronic.com		Northern Road Newark Nottinghamshire NG24 2ET (+44) 01636 610062	
Client:	Client' Name		
Project:	Project's Name		
Drawing:	Electrical Connections Array B		
Dwg No:	DPxxx/x/5	Issue 1	Scale: NTS
Drawn:	xxx	Date:	xx/xx/xxxx Chkd: xxx
Room:	Room 1	Sheet 5 of 5	